

KD18HUF

18"Rebel

Assembly Manual

332/4453

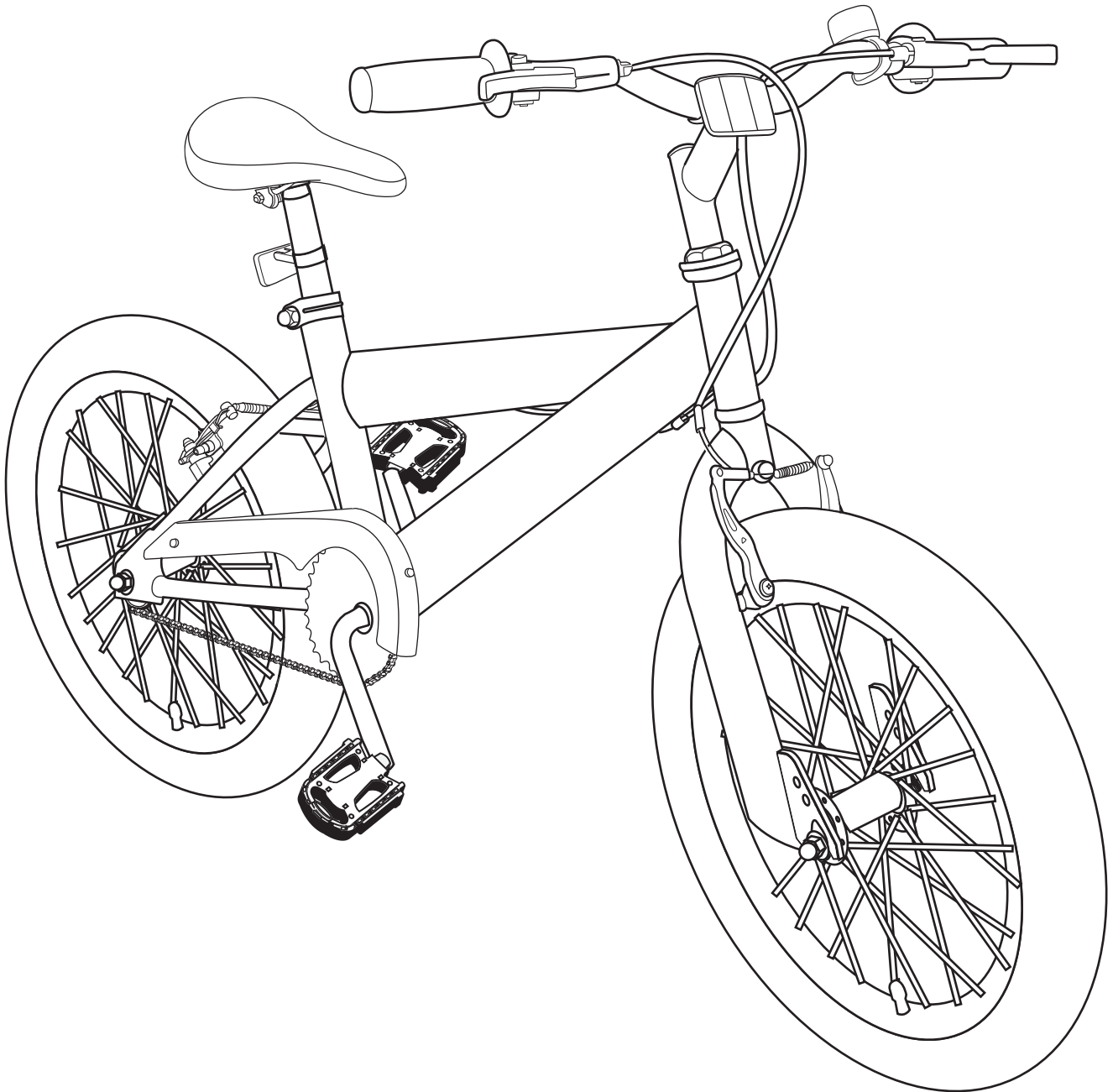

Important - Please read these instructions fully before starting assembly

These instructions contain important information that will help you get the best from your bike, ensuring safe and correct assembly, use and maintenance.

If you need help or have damaged or missing parts, call the **Customer Helpline on 0345 640 0800**

Assembly	5
Step 1	5
Step 2	6
Step 3	8
Step 4	9
Step 5	10
Step 6	13
Riding Advice	14
Before Riding	14
Using the Brakes	14
Riding in Bad Weather	15
Riding in the Dark	15
Riding Using Personal Music Players	15



Safety Information

Customer Helpline 0345 640 0800

Important - Please read these instructions carefully before starting assembly



WARNING! This Bike has been designed, assembled and tested in accordance with the BS EN 14764:2005 standard to ensure your safety. To make sure the bike remains safe. It should only be used for recreational use. Under no circumstances should it be used for competitive cycling, stunting, jumping or acrobatic manoeuvres. These types of cycling may result in serious personal injury and damage to the bike.

WARNING! Always wear a cycle helmet when riding the bike. The helmet should be the correct size for your head and must conform to the European Standard EN1078:1997.

WARNING! When riding in the dark, always make sure that the bike is fitted with suitable reflectors and use a white front light and a red light.

WARNING! Always take extra care when riding in wet, foggy, windy, or icy conditions. The brakes may not be as effective and the braking distances may be increased.

WARNING! Always wear suitable cycling clothing when riding the bike. Loose clothing which may get caught in moving parts should be avoided.

WARNING! This bike is only suitable for use by riders (including any panniers and/or luggage) with a weight of less than 100 kg (220 lb).

WARNING! When assembling the handlebars and stem to the bike frame, make sure the forks are facing in the correct direction. If the forks are assembled correctly, the brakes should be facing forward. Failure to observe the warning may affect their correct operation and may lead to personal injury and damage to the bike.

WARNING! When assembling the seatpost, make sure it is inserted beyond the minimum insert mark. Failure to observe this warning may lead to a potentially unstable seat post and may result in serious personal injury.

WARNING! The front and rear tyres must be fully inflated before attempting to ride the bike. Under no circumstances should the tyres be inflated above the maximum pressure stated on the side of the tyres.

WARNING! Only inflate the front and rear tyres of the bike using a bicycle pump. Do not attempt to use another type of pump to inflate the tyres.

WARNING! As with all mechanical components, the bike is subjected to wear and high stresses. Different materials and components may react to wear, stress or fatigue in different ways. If the design life of a component has been exceeded, it may suddenly fail, possibly causing injuries to the rider. Any form of crack, scratches or change of colouring in highly stressed areas indicate that the life of the component has been reached and it should be replaced.

WARNING! Ensure only genuine replacement parts are used, especially for safety critical parts.



Safety Information

Customer Helpline 0345 640 0800

Important - Please read these instructions carefully before starting assembly



CAUTION! Only use suitable tools to assembled the bike. The use of unsuitable tools may lead to personal injury and damage to the bike.

CAUTION! Always ensure all packaging is removed from the bike before assembly and use. Failure to remove the packaging may prevent the correct operation and may lead to personal injury and damage to the bike.

CAUTION! The safety and smooth running of the bike can only be preserved with regular maintenance. Always ensure the bike is maintained in accordance with the supplied maintenance manual.

CAUTION! Before attaching the handlebar assembly, make sure all cables are free to move and are not tangled. Failure to observe this caution may prevent correct operation and may lead to personal injury and damage to the bike.



IMPORTANT! Before assembling the bike, check all the parts idicated in the manual are in the box. Inspect the parts for signs of damage. Do not assemble the bike if you observe any damaged components.

IMPORTANT! Always take care when removing the packaging to prevent damage to the bike.



NOTE! Always take recycle the packaging in accordance with local recycling schemes.

NOTE! The pedals and crank arms have colour coded stickers to indicate which pedal matches which Crank Arm.

NOTE! The threads on the left and right pedals are different .To prevent damage to the threads, only tighten the pedals in the direction indicated on the stickers and marked on the end of pedals.

NOTE! The tires may have a direction of rotation arrow embossed on the side of the tire. When the front wheel is assembled, the arrow should be pointing in the direction that the wheel will rotate.

Recommended Tightening Information

While assembling the bike, it is recomended that, where possible, a torque wrench is used to tighten nuts and bolts. The table below provides a list of torque setting for the various nuts and bolts.

Part	Torque (Nm)
Stem bolt	17-19 Nm
Seat post bolt	8-10 Nm
Saddle clamp nuts	16-18 Nm
Pedals	40 Nm
Front wheel nuts	22-25 Nm
Rear wheel nuts	25-29 Nm

Step 1



IMPORTANT! Before assembling the bike, check all the parts indicated in the manual are in the box. Inspect the parts for sign of damage. Do not assemble the bike if you observe any damage components.

IMPORTANT! Always take care when removing the packaging to prevent damage to the bike.

1. Remove the bike from the box and carefully remove all packaging. The following types of packaging are used to protect the bike during transit:
 - Cardboard Wrapping - This is used to protect the painted surfaces of the bike frame.
 - Cable Ties - These are used to secure loose parts to the partially assembled bike.
 - Stem Caps - These are placed in unprotected ends of the bike frame.
 - Axle Protectors - These are used to protect the outer edges of the front and rear wheel axles.
 - Fork Protectors - These are used to prevent the forks from bending or being damage.
 - Handlebar Stem Protector - This is used ensure the wedge nut remains in the correct orientation during transit.
2. The Pakcaging should be retained until the bike is fully assembled. Use the box to store the packaging during assembly.



NOTE! Always recycle the packaging in accordance with local recycling schemes.

Step 2

2a

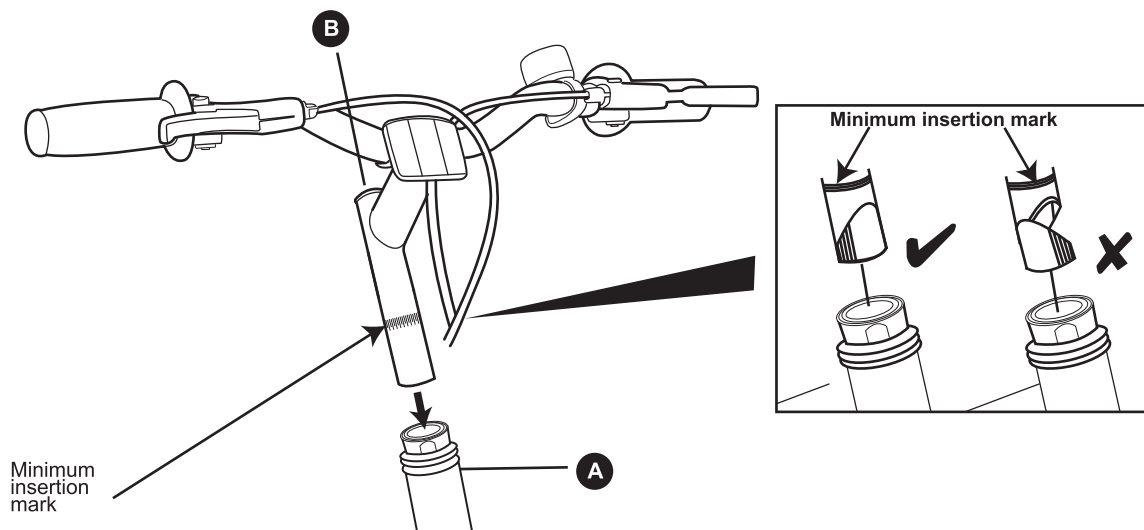

2a Insert the Stem



WARNING! When assembling the handlebars and stem, make sure it is inserted beyond the **minimum insert mark**. Failure to observe this warning may lead to a potentially unstable bike and may result in serious personal injury.

If necessary loosen the stem bolt at the top of the handlebars and stem **B** to allow the wedge nut to move freely.

Ensuring the wedge nut is correctly aligned, insert the lower end of the handlebars and stem **B** into the head tube of the bike **A**.

Step 2 (continued)

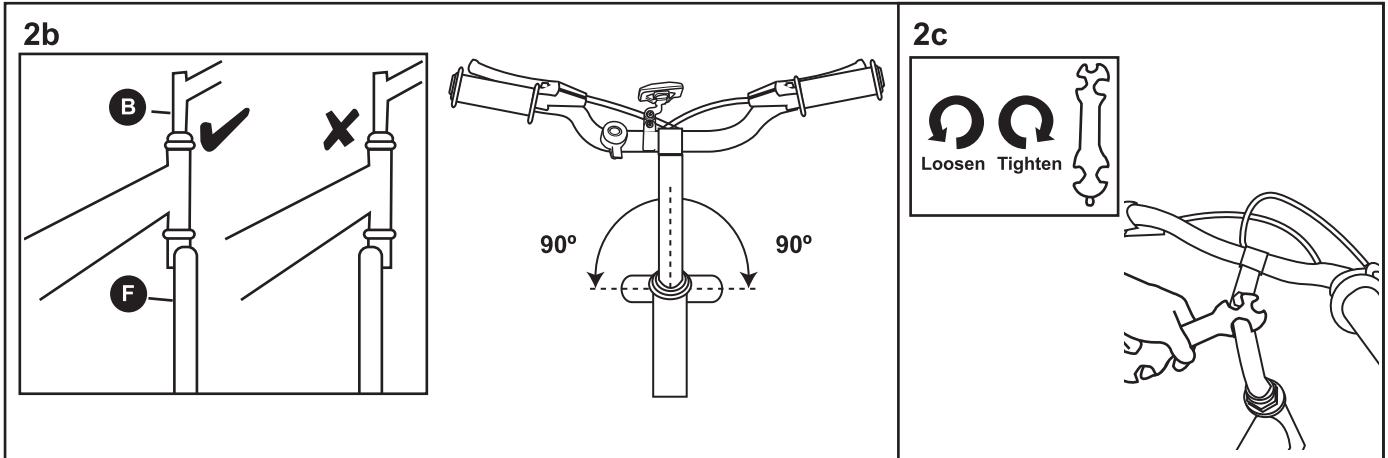

2b Align the Stem



WARNING! When assembling the handlebars and stem to the bike frame make sure the forks are facing in the correct direction. If the forks are assembled correctly, the front brake should be facing forwards. Failure to observe this warning may prevent their correct operation and may lead to personal injury and damage to the bike.

Adjust the handlebars and stem (B) to the desired height and align with the forks (F). The forks must be facing in the right direction as shown.

2c Securing the stem

Using the supplied spanner wrench, tighten the stem bolt firmly.

Step 3

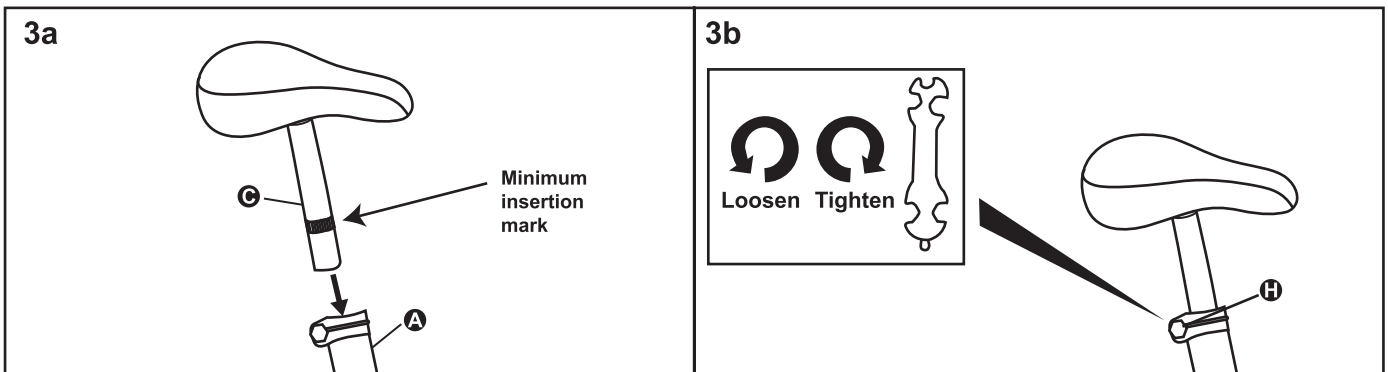

3a Insert the Seat Post and Saddle



WARNING! When assembling the seat post, make sure it is inserted beyond the minimum insert mark. Failure to observe this warning may lead to a potentially unstable seat post may result in serious personal injury.

Insert the lower end of the seat post and saddle (C) into the seat tube of the bike (A).

3b Securing the Seat Post

Using the supplied spanner wrench tighten the seat post bolt (H) firmly.

Step 3

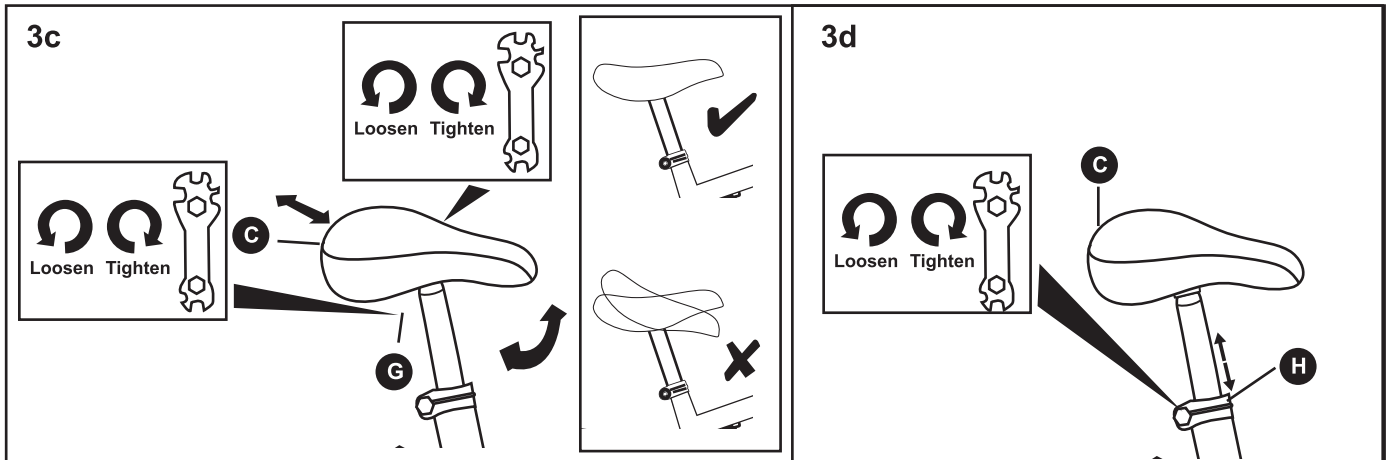

3c Adjusting the Position of the Saddle

The angle of the saddle **C** should be adjusted so that it is horizontal to the floor. To adjust the tilt of the saddle, loosen the saddle clamp nuts **G** a quarter of a turn at a time using the multitool supplied until the saddle can be moved.

If required, the saddle **C** can be moved forwards or backwards on the seat post while the saddle clamp nuts **G** are loose.

Once the saddle **C** is positioned correctly, retighten the saddle clamp nuts **G**.

3d Adjusting the Height of the Saddle

The height of the saddle **C** should be adjusted so that the Rider can comfortably touch the ground with both feet. To adjust the height of the saddle **C**, loosen the seat post bolt **H** until the seat post can move freely.

Once the saddle **C** is positioned correctly, retighten the seat post bolt **H**.



WARNING! When assembling the seat post, make sure it is inserted beyond the minimum insert mark. Failure to observe this warning may lead to a potentially unstable seat post and may result in serious personal injury.

Step 4

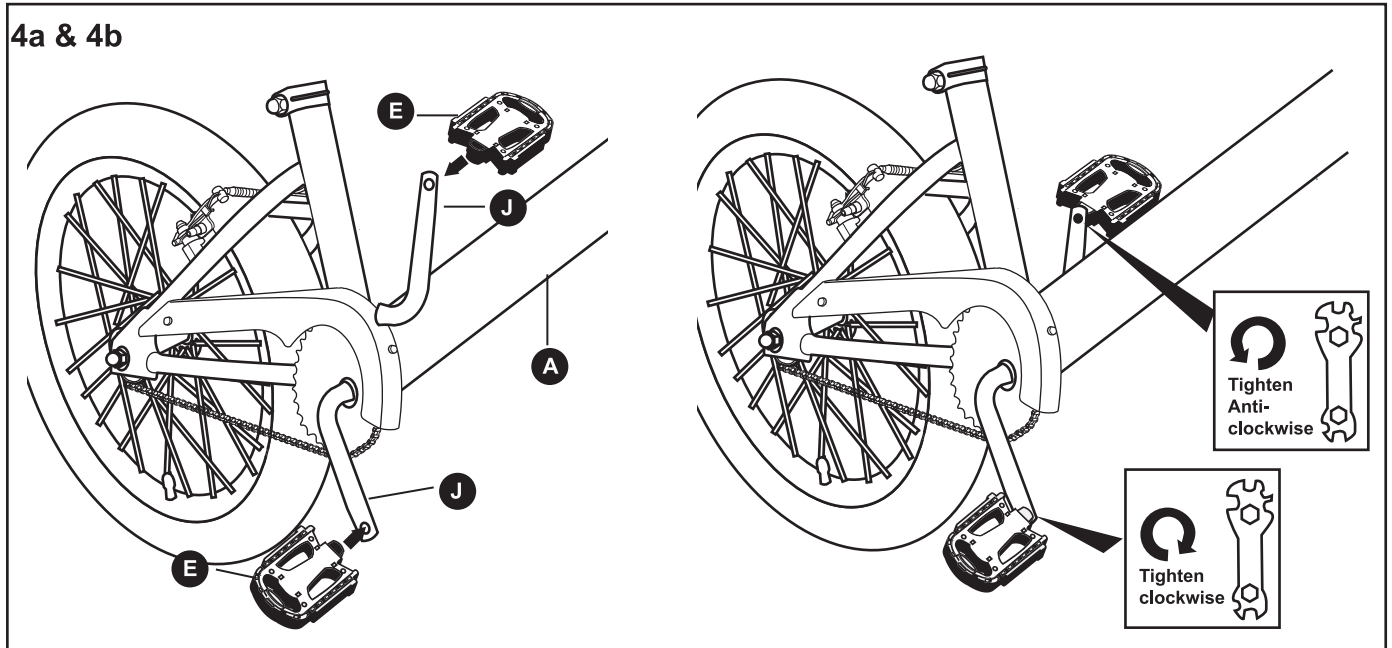

NOTE

NOTE! The pedals **E** and crank arms **J** have colour coded stickers to indicate which pedal **E** matches which crank arm **J**.

NOTE! The threads on the left and right pedals are different. To prevent damage to the threads, only tighten the pedals in the direction indicated on the stickers and marked on the end of pedals.

4a Fitting the Right Hand Pedal

Locate the right hand pedal **E**. This will have a blue sticker attached.

Locate the right hand crank arm **J** on the bike **A**. This will also have a blue sticker attached.

Insert the threaded shaft to the right hand pedal **E** in to the threaded hole of the right hand crank arm **J**. Initially tighten the pedal using only your fingers in the direction indicated on the colour coded stickers. Fully tighten using multitool supplied.

4b Fitting the Left Hand Pedal

Locate the left hand pedal **E**. This will have a red sticker attached.

Locate the left hand crank arm **J** on the bike **A**. This will also have a red sticker attached.

Insert the threaded shaft to the left hand pedal **E** into the threaded hole of the left hand crank arm **J**. Initially tighten the pedal using only your fingers in the direction indicated on the colour coded stickers. Fully tighten using multitool supplied.

Step 5

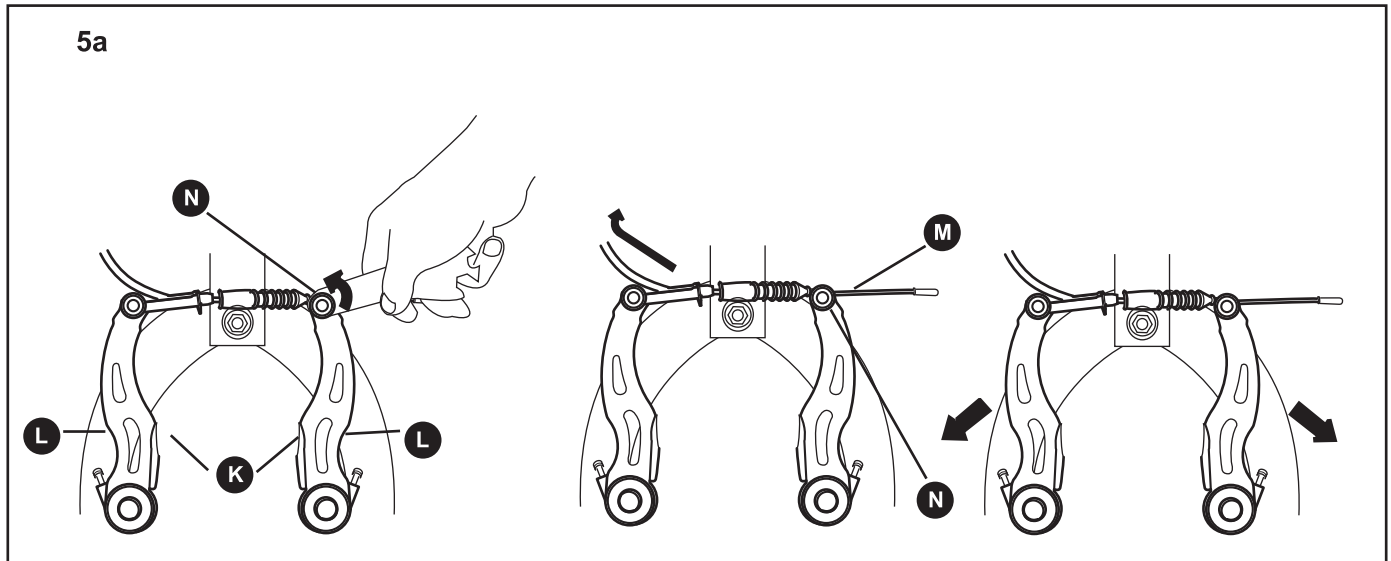

5a Loosen Adjustment the Front Brake

Before the front wheel **D** can be installed, the front brake **K** must be loosen. This allows the front tyre to pass between the brake during assembly.

Loosen the Cable Pinch bolt **N** to release the brake cable and open the calipers.

Step 5 (continued)

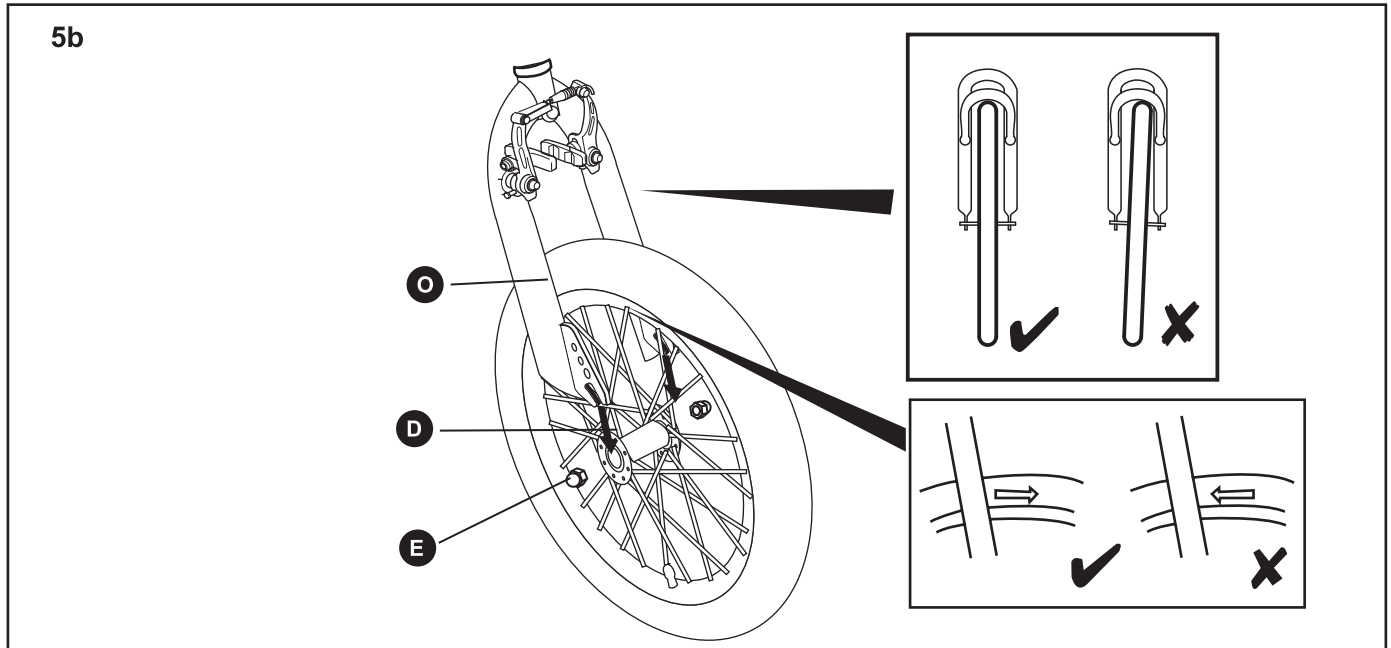

5b Insert the Wheel

Loosen the wheel nuts **E** on both ends of the front wheel **D** axle.



NOTE! The tyres may have a 'Direction of Rotation' arrow embossed on the side. When the front wheel **D** is assembled, the arrow should be pointing in the direction that the wheel will rotate.

Insert the axle of the front wheel **D** into the slots at the bottom of the forks **O**.

While ensuring the wheel is centralised in the forks **O**, fully tighten the wheel nuts **N** using the supplied multitool.

Step 5 (continued)

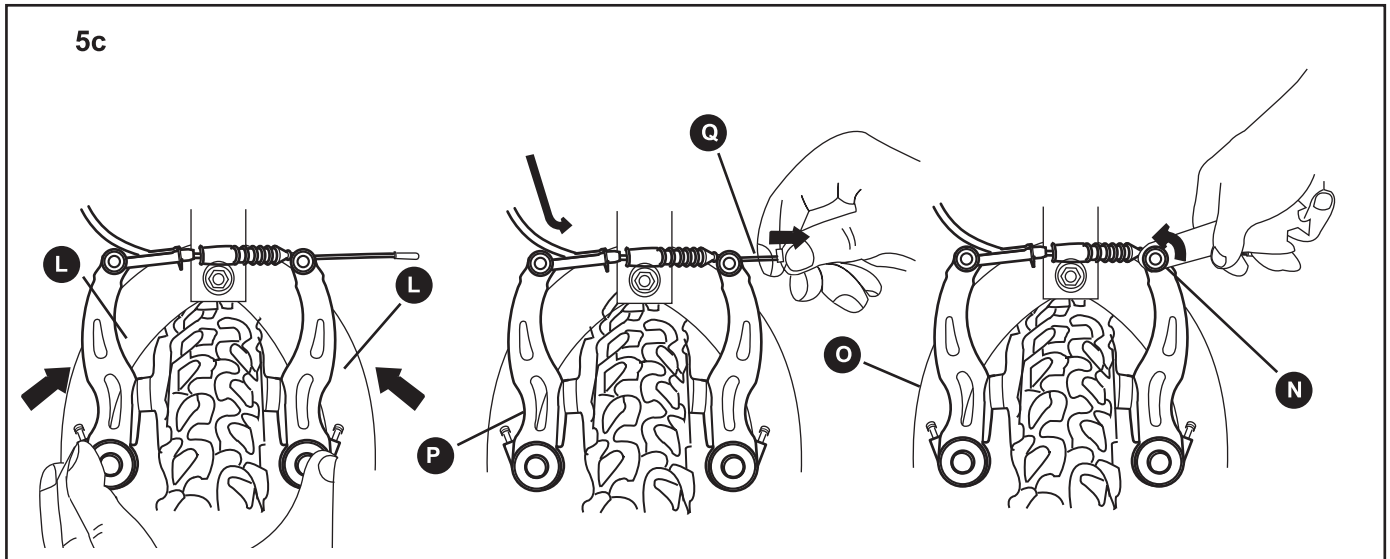

5c Re-Adjust the Front Brake

Squeeze the two arms **L** of the front brake **K** together with one hand.

Check that the brake pads **P** line up with the rim, and do not touch the tyre. Adjust their position if necessary. Ensure that the brake pads **P** are the same distance from the rim.

Adjust the brake cable tension by pulling the cable wire **Q** downwards and retighten the cable pinch bolt **N**.

Check that the front wheel **D** rotates freely. If it does not, the front wheel **D** may not be located centrally between the forks **O**. Alternatively, the front brake may need adjusting. Please refer to the supplied Maintenance Manual.

Step 6

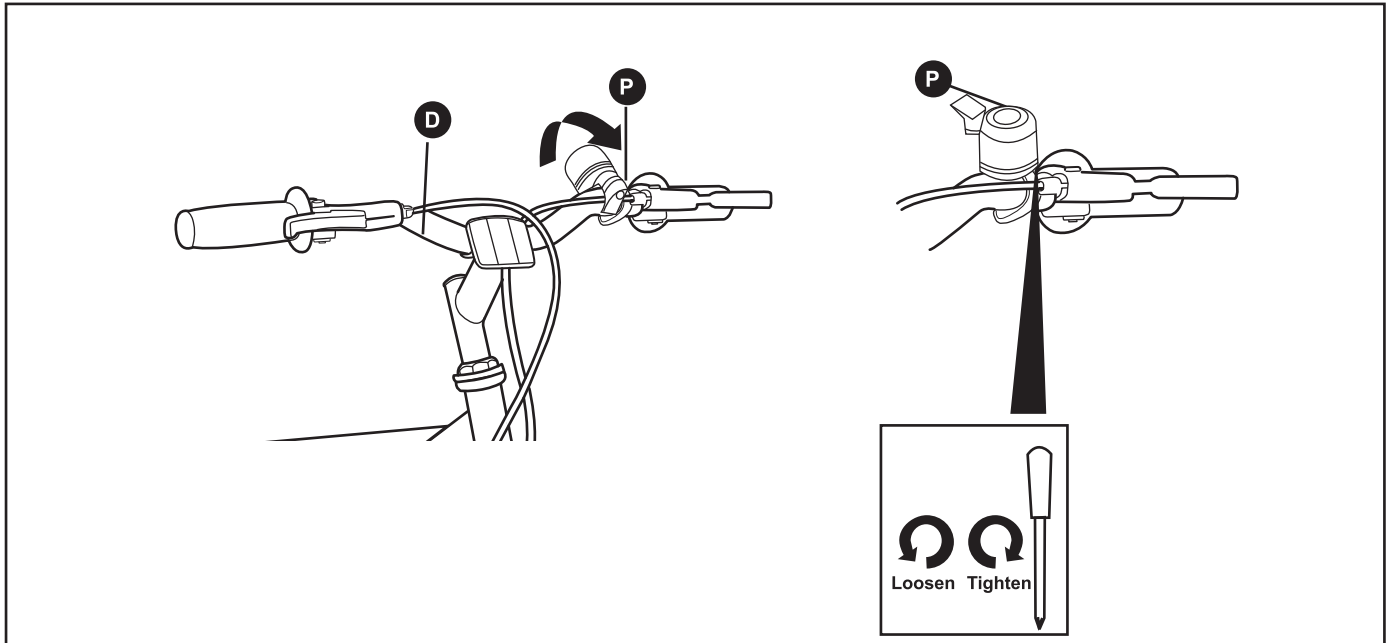

Position the Bell

Rotate the bell **P** so it is upright and position it along the length of the handlebars **D**. You must be able to operate the bell **P** without removing your hand from the handlebars.

Using a suitable screwdriver, tighten the retaining screw at the bottom of the bell **P**.

Before Riding

You should perform the following checks before riding your bike to ensure it is safe to use and operating correctly.

1. Is the saddle Secure?

While standing next to the bike, try and move the saddle from side to side. If the saddle moves you should retighten the seat post bolt or the saddle clamp bolts.

2. Are the Front and Rear Tyres Inflated Correctly?

Squeeze the sides of the front and rear tyres. If they are soft they will need inflating. Re - inflate to the pressure indicated on the sides of the tyres using approved bicycle pump.

3. Are the Pedals Tight?

Using the supplied multitool, ensure both the left and right pedals are fully tight. Remember that the threaded shafts of the left and right pedals tighten in different directions.

4. Do the Brakes Work?

Stand next to the bike and apply the front brake and push forwards. If the wheels move, the front brake may not be working correctly. If required, adjust the front brakes as described in the Maintenance Manual.

Repeat the above check for the rear brake.

5. Do the Handlebars Move?

Hold the front wheel between your legs and try to move the handlebars . If the handlebars move, the stem bolt may have become loose. Retighten the stem bolt.

6. Is the bike Clean?

The bike should be cleaned and re-oiled regularly to ensure it operates correctly.

Using the Brakes

The bike is fitted with front and rear brakes to stop the bike effectively.

The brakes are operated using two brake lever mounted on the handle bars . The left hand brake lever operates the rear brake and the right hand brake lever operates the front brake.

Riding in Bad Weather

 **WARNING!** Always take extra care when riding in wet, foggy, windy or icy conditions. The brakes may not be as effective and the braking distances may be increased.

When riding in bad weather i.e. wet, foggy, windy or icy, always wear bright, reflective clothing which is warm and waterproof.

You should always give other road users clear signals n plenty of time particularly when approaching junctions. Always brake earlier than you would in the dry as the required braking distance will be increased.

Be aware that all types of surface become greasy or slippery i bad weather. Do not turn or brake suddenly.

Riding in the Dark

 **WARNING!** When riding in the dark, always make sure that the bike is fitted with suitable reflectors and a white front light and a red rear light.

It is essential that other road users can clearly see you when riding in the dark. Always wear bright, reflective clothing. Suitable reflectors should be fitted to the front and rear of the bike and if possible the wheels. A white light must be fitted to the front of the bike and a red light at the rear.

Before starting any journey in the dark or even twilight, ensure the lights are working correctly and are turned on.

Clean lights and reflectors regularly and make sure they can be seen from distance.

Riding Using Personal Music Players

It is recommended that personal music players are not used while riding a bike. These devices prevent you from hearing approaching vehicles and may prove to be a distraction.

